

The LGT2 and MGT provide lighter load alternatives for girder tiedowns. The HGT-4 is sized for 4-2x widths. This series provides high uplift resistance for wood frame and concrete block construction. The HGT can be installed on trusses and beams with top chord slopes from 3:12 to 8:12. Available in 2-ply, 3-ply and 4-ply widths.

MATERIAL: LGT—14 ga; MGT—12 ga; HGT—7 ga.

FINISH: HGT—Simpson gray paint;
LGT, MGT—galvanized

INSTALLATION: • When the HGT-3 is used with a 2-ply girder or beam, shimming is required. Fasten to act as one unit.

- Attach to grouted concrete block **with a minimum one #5 rebar horizontal in the top lintel block.**
- **Minimum $f'_c = 2500$ psi maximum aggregate $\frac{3}{8}$ ".**

CODES: See page 8 for Code Listing Key Chart.

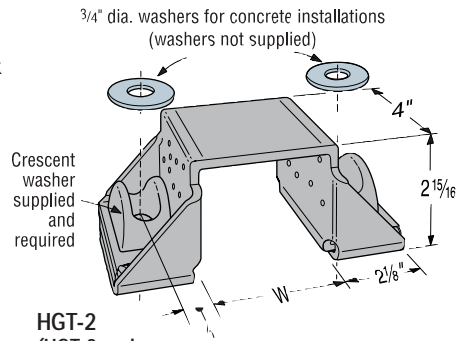

HGT-2
(HGT-3 and HGT-4 similar)

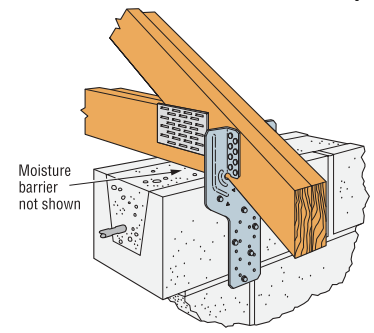

Typical LGT2
Installation into Concrete

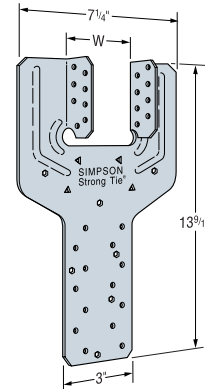

LGT2

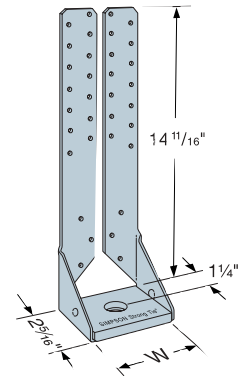

MGT

Model No.	W	O.C. Dim Between Anchors	Fasteners		Avg Ult	DFL/SP Allowable Loads (133/160)	SPF Allowable Loads (133/160)	Code Ref.
			Anchor Dia.	Girder				
MGT	3 3/4	—	1-5/8	22-10d	13005	3965	3330	160
HGT-2	3 5/8	5 3/4	2-3/4	16-10d	35400	10980	6485	6
HGT-3	4 1/16	7 3/8	2-3/4	16-10d	35580	10530	9035	
HGT-4	6 1/16	9	2-3/4	16-10d	28805	9250	9250	
Masonry Application								
Model No.	W	O.C. Dim Between Anchors	Fasteners		Avg Ult	DFL/SP Allowable Loads (133/160)	SPF Allowable Loads (133/160)	Code Ref.
			Block	Girder				
LGT2	3 3/8	—	7-1/4x2 1/4 Titen	16-16d sinker	6533	2150	1850	160

1. Attached members must be designed to resist applied loads.
2. To achieve the loads listed, anchorage into a concrete block bond beam shall be designed by the building designer.
3. To achieve the loads listed, anchorage into a 8" wide concrete tie-beam can be made using Simpson SET epoxy with a 3/4" diameter anchor and a minimum embedment depth of 12".
4. Allowable loads have been increased 33% and 60% for earthquake or wind loading; no further increase allowed; reduce where other loads govern.

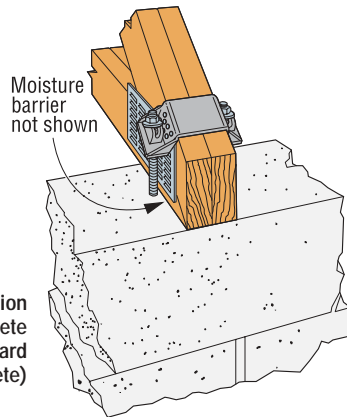

Typical HGT-2 Installation
into Concrete
(3/4" diameter standard washers required for concrete)

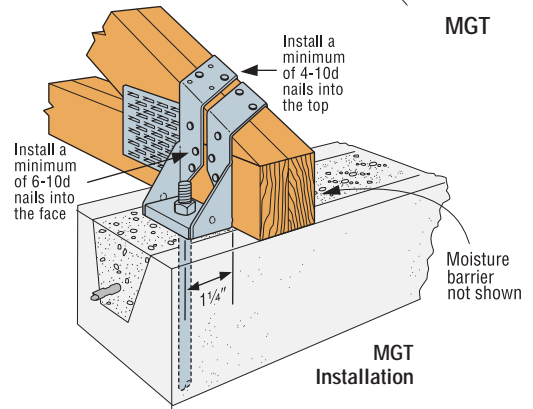

MGT Installation