

TOP FLANGE HANGERS W/WPU/WNP/WM/WMU/HW/HWU

The W, WPU, HWU and HW series purlin hangers offer the greatest design flexibility and versatility. WMs are designed for use on standard 8" grouted masonry block wall construction.

MATERIAL: See tables on pages 56 to 58; W—12 ga. top flange and stirrup; WM, WMU—12 ga. top flange and stirrup; WNP, WP, WPU—7 ga. top flange, 12 ga. stirrup; HW—3 ga. top flange, 11 ga. stirrup; HWU—3 ga. top flange, 10 ga. stirrup.

FINISH: Simpson gray paint; hot-dipped galvanized available; specify HDG.

ALLOWABLE LOADS: For hanger heights exceeding the joist height, the allowable load is 0.50 of the table load.

INSTALLATION: • Use all specified fasteners. WM—two 16d duplex nails must be installed into the top flange and embedded into the grouted wall. Verify that the header can take the required fasteners specified in the table.

- Hangers may be welded to steel headers with **weld size to match material thickness (approximate thickness shown)** 1/8" for W, 3/16" for WNP, and 1/4" for HW, by 1/2" fillet welds located at each end of the top flange. Weld-on applications produce maximum allowable load listed. Uplift loads do not apply to this application.
- Hangers can support multi-ply carried members; the individual members must be secured together to work as a single unit before installation into the hanger.
- H dimensions are sized to account for normal joist shrinkage. W dimensions are for dressed timber widths.
- Embed WM into block with a minimum of one course above and one course below the top flange with one #5 vertical rebar minimum 24" long in each cell. **Minimum grout strength is 2000 psi.**
- See Hanger Options, page 147 for hanger modifications and associated load reductions.

CODES: See page 8 for Code Listing Key Chart.

Model	Nailer	Top Flange Nailing	Allowable Down Loads		
			DF/SP	SPF	LSL
W	2x	2-10dx1 1/2	1600	1600	—
	3x	2-16dx2 1/2	1765	1740	—
	2-2x	2-10d	1665	1665	—
	4x	2-10d	2200	2200	—
WP and WNP	2x	2-10dx1 1/2	2525	2500	3375
	3x	2-16dx2 1/2	3000	2510	3375
	2-2x	2-10d	3255	3255	—
	4x	2-10d	3255	3255	—
HW	4x	4-16d	5285	—	—

NAILER TABLE

The table indicates the maximum allowable loads for W, WNP and HW hangers used on wood nailers. Nailers are wood members attached to the top of a steel I-beam, concrete or masonry wall. This table also applies to sloped-seat hangers.

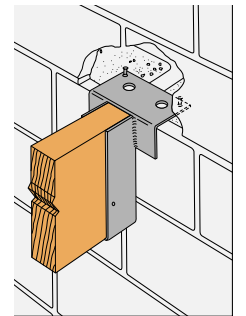
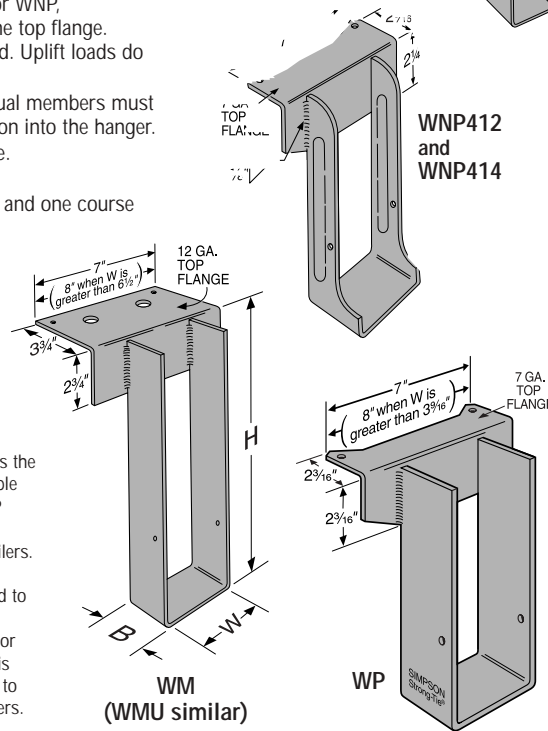
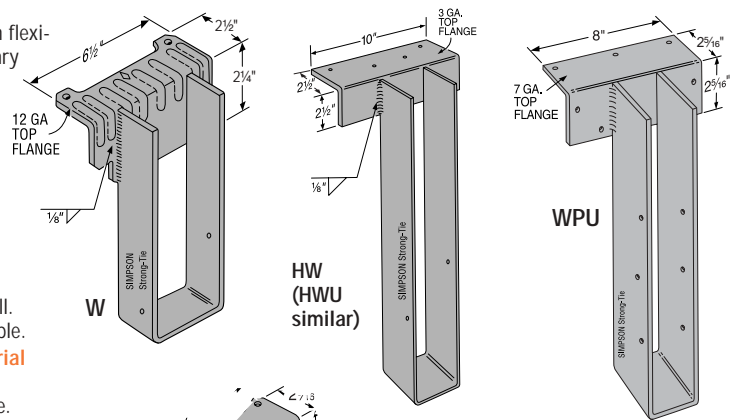

Typical WM Installation

Some model configurations may differ from those shown. Call factory for details.

W SERIES WITH VARIOUS HEADER APPLICATIONS

Model	Joist		Fasteners			Allowable Loads Header Type							Code Ref.	
	Width	Depth	Top	Face	Joist	Uplift (133 & 160)	LVL	PSL	LSL	DF/SP	SPF	I-Joist		Masonry
W	1 1/2 to 4	3 3/8 to 30	2-10dx1 1/2	—	2-10dx1 1/2	—	1635	1740	—	1600	1415	—	—	170
	1 1/2 to 4	3 3/8 to 30	2-10d	—	2-10dx1 1/2	—	2150	2020	—	2200	1435	—	—	26, 83
	1 1/2 to 4	3 3/8 to 30	2-16d	—	2-10dx1 1/2	—	2335	1950	2335	1765	1435	—	—	—
WM	1 1/2 to 7 1/2	3 3/8 to 30	2-16d DPLX	—	2-10dx1 1/2	—	—	—	—	—	—	—	4175	1, 36, 84, 120
WMU	1 1/2 to 7 1/2	9 to 18	2-16d DPLX	4-1/2x1 1/4" Titens	6-10dx1 1/2	660	—	—	—	—	—	—	4175	170
	1 1/2 to 7 1/2	18 1/2 to 22 1/2	2-16d DPLX	4-3/4x1 1/4" Titens	6-10dx1 1/2	660	—	—	—	—	—	—	4175	170
	1 1/2 to 7 1/2	23 to 28	2-16d DPLX	4-1/2x1 1/4" Titens	6-10dx1 1/2	625	—	—	—	—	—	—	4175	170
WP/WNP	1 1/2 to 7 1/2	3 3/8 to 30	3-10dx1 1/2	—	2-10dx1 1/2	—	2865	3250	—	2500	2000	2030	—	170
	1 1/2 to 7 1/2	3 3/8 to 30	3-10d	—	2-10dx1 1/2	—	2525	3250	3650	3255	2525	—	—	26, 83
	1 1/2 to 7 1/2	3 3/8 to 30	3-16d	—	2-10dx1 1/2	—	3635	3320	3650	3255	2600	—	—	—
WPU/WNPU	1 3/4 to 5 1/2	7 1/4 to 18	3-16d	4-16d	6-10dx1 1/2	775	4700	4880	3650	4165	4165	—	—	26
	1 3/4 to 5 1/2	18 1/2 to 22 1/2	3-16d	4-16d	6-10dx1 1/2	485	4700	4880	3650	4165	4165	—	—	26
	1 3/4 to 5 1/2	23 to 28	3-16d	4-16d	6-10dx1 1/2	315	4700	4880	3650	4165	4165	—	—	26
HW	1 1/2 to 7 1/2	3 3/8 to 32	4-10d	—	2-10dx1 1/2	—	3100	4000	—	5285	3100	—	—	26, 83
	1 1/2 to 7 1/2	3 3/8 to 32	4-16d	—	2-10dx1 1/2	—	5100	4000	4500	5285	3665	—	—	26, 83
HWU	1 3/4 to 3 1/2	9 to 18	4-16d	4-16d	6-10dx1 1/2	810	6335	5500	5535	6335	5415	—	—	26
	1 3/4 to 3 1/2	18 1/2 to 22 1/2	4-16d	4-16d	6-10dx1 1/2	765	6335	5500	5535	6335	5415	—	—	26
	1 3/4 to 3 1/2	23 to 28	4-16d	4-16d	6-10dx1 1/2	635	6335	5500	5535	6335	5415	—	—	26
	1 3/4 to 3 1/2	28 1/2 to 32	4-16d	4-16d	8-10dx1 1/2	1005	6335	5500	5535	6335	5415	—	—	26
	4 1/2 to 7	9 to 18	4-16d	4-16d	6-10dx1 1/2	810	6000	5500	5535	6000	5415	—	—	26
	4 1/2 to 7	18 1/2 to 22 1/2	4-16d	4-16d	6-10dx1 1/2	765	6000	5500	5535	6000	5415	—	—	26
	4 1/2 to 7	23 to 28	4-16d	4-16d	6-10dx1 1/2	635	6000	5500	5535	6000	5415	—	—	26
4 1/2 to 7	28 1/2 to 32	4-16d	4-16d	8-10dx1 1/2	1005	6000	5500	5535	6000	5415	—	—	26	

1. 16d sinkers (9 ga x 3") may be used where 10d commons are called out with no load reduction.
2. Code values are based on DF/SP header species.

3. WMU, WPU and HWU uplift loads have been increased 33% and 60% for wind or earthquake loading; no further increase allowed. Divide by 1.33 and 1.60 for normal loading like cantilever construction.