

A custom connection for post-beam combinations at medium design loads.

MATERIAL: PC—12 gauge; PC-16—16 gauge

FINISH: Galvanized. Some products available in Z-MAX; see Corrosion Resistance information below.

INSTALLATION: • Use all specified fasteners; see General Notes.

- If 9/16" tooling holes are bolted, no additional load is achieved.

OPTIONS: • For end conditions, specify EPC post caps, providing dimensions are in accordance with table; see illustration.

- Some PC and EPC models are available in rough sizes.
- For heavy duty applications, see also CC series.

CODES: See page 8 for Code Listing Key Chart.

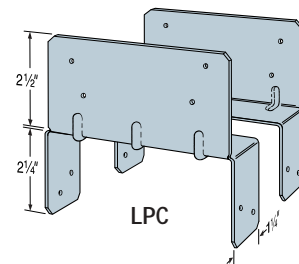
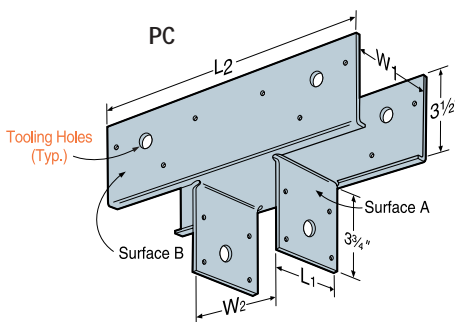

Model No.	Min Post Size	DIMENSIONS					Fasteners each side			Uplift Avg Ult	Allowable Loads				Code Ref.
		W ₁	W ₂	L ₁	L ₂	L ₃	Surfaces				Uplift PC/EPC		Lateral ²		
							A	B	C		(133)	(160)	PC (133/160)	EPC (133/160)	
PC44-16	4x4	3 9/16	3 3/16	2 5/8	11	7 5/16	4-16d	6-16d	4-16d	3433	1000	1000	925	1000	7, 40, 90
PC44	4x4	3 9/16	3 3/16	2 5/8	11	7 5/16	4-16d	6-16d	4-16d	4933	1470	1700	925	1070	
PC46-16	4x6	3 9/16	5 1/2	2 5/8	13	9 1/4	4-16d	6-16d	4-16d	3433	1000	1000	925	1000	
PC46	4x6	3 9/16	5 1/2	2 5/8	13	9 1/4	4-16d	6-16d	4-16d	4933	1470	1700	925	1070	
PC48-16	4x8	3 9/16	7 1/2	2 5/8	15	11 1/4	4-16d	8-16d	6-16d	3433	1000	1000	1475	1285	
PC48	4x8	3 9/16	7 1/2	2 5/8	15	11 1/4	4-16d	8-16d	6-16d	4933	1470	1700	2075	1610	
PC64-16	4x6	5 1/2	3 3/16	4 9/16	11	7 3/8	4-16d	6-16d	4-16d	3433	1000	1000	925	1000	
PC64	4x6	5 1/2	3 3/16	4 9/16	11	7 3/8	4-16d	6-16d	4-16d	4933	1470	1700	925	1070	
PC66-16	6x6	5 1/2	5 1/2	4 9/16	13	9 1/4	4-16d	6-16d	6-16d	3433	1000	1000	925	1285	
PC66	6x6	5 1/2	5 1/2	4 9/16	13	9 1/4	4-16d	6-16d	6-16d	4933	1470	1700	925	1610	
PC68	6x8	5 1/2	7 1/2	4 9/16	15	11 1/4	4-16d	8-16d	6-16d	4933	1470	1700	2075	1610	
PC84	4x8	7 1/2	3 3/16	6 1/16	11	7 3/8	4-16d	6-16d	6-16d	4933	1470	1700	925	1610	
PC86	6x8	7 1/2	5 1/2	6 1/16	13	9 1/4	4-16d	6-16d	6-16d	4933	1470	1700	925	1610	
PC88	8x8	7 1/2	7 1/2	6 1/16	15	11 1/4	4-16d	8-16d	6-16d	4933	1470	1700	2075	1610	

1. Allowable loads have been increased 33% and 60% for earthquake or wind loading with no further increase allowed; reduce where other loads govern.
2. Lateral loads are in the direction parallel to the beam.
3. Allowable loads are for nails only.

4. Uplift loads do not apply to splice conditions.
5. Spliced conditions must be detailed by the specifier to transfer tension loads between spliced members by means other than the post cap.

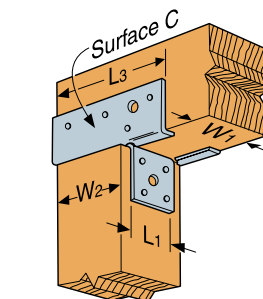

Typical EPC End Post Cap Installation

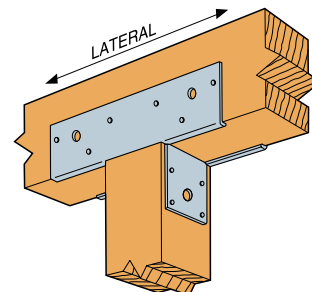

Typical PC Post Cap Installation