

TOP FLANGE HANGERS W/WP/WPU/WM/WMU/HW/HWU

I-JOIST AND STRUCTURAL COMPOSITE LUMBER HANGERS

The W, WP, WPU, HWU and HW series purlin hangers offer the greatest design flexibility and versatility. WMs are designed for use on standard 8" grouted masonry block wall construction.

MATERIAL: See tables on pages 80 to 93; W, WI—12 ga. top flange and stirrup;
WM, WMI, WMU—12 ga. top flange and stirrup; WPU, WP—7 ga. top flange, 12 ga. stirrup;
HW, HWI—3 ga. top flange, 11 ga. stirrup; HWU—3 ga. top flange, 10 ga. stirrup.

FINISH: Simpson gray paint; hot-dipped galvanized available; specify HDG.

ALLOWABLE LOADS: For hanger heights exceeding the joist height, the allowable load is 0.50 of the table load.

INSTALLATION: • Use all specified fasteners. WM—two 16d duplex nails must be installed into the top flange and embedded into the grouted wall. Verify that the header can take the required fasteners specified in the table.

- Hangers may be welded to steel headers with 1/8" for W, WI, 3/16" for WP, WPI, and 1/4" for HW, HWI, by 1 1/2" fillet welds located at each end of the top flange. Weld-on applications produce maximum allowable load listed. Uplift loads do not apply to this application.
- Hangers can support multi-ply carried members; the individual members must be secured together to work as a single unit before installation into the hanger.
- Embed WM into block with a minimum of one course above and one course below the top flange with one #5 vertical rebar minimum 24" long in each cell. **Minimum grout strength is 2000 psi.**
- Web stiffeners are required for standard joist nailing configuration with this hanger.

OPTIONS: • Specify alternate nailing pattern when web stiffeners are not being used (up to 16" in depth). Add X ANP after model number for nailing into the flange, available for 90° applications only. Uplift loads do not apply to this application.

- See Hanger Options, page 147 for hanger modifications and associated load reductions.

CODES: See page 8 for Code Listing Key Chart.

Model	Nailer	Top Flange Nailing	Allowable Loads		
			DF/SP	SPF	LSL
W/WI	2x	2-10dx1 1/2	1600	1600	—
	3x	2-16dx2 1/2	1765	1740	—
	2-2x	2-10d	1665	1665	—
	4x	2-10d	2200	2200	—
WP/WPI	2x	2-10dx1 1/2	2525	2500	3375
	3x	2-16dx2 1/2	3000	2510	—
	2-2x	2-10d	3255	3255	—
	4x	2-10d	3255	3255	—
HW/HWI	4x	4-16d	5285	—	—

NAILER TABLE

The table indicates the maximum allowable loads for W, WP and HW hangers used on wood nailers. Nailers are wood members attached to the top of a steel I-beam, concrete or masonry wall. This table also applies to sloped-seat hangers.

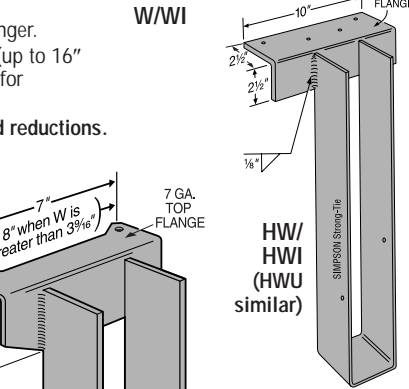
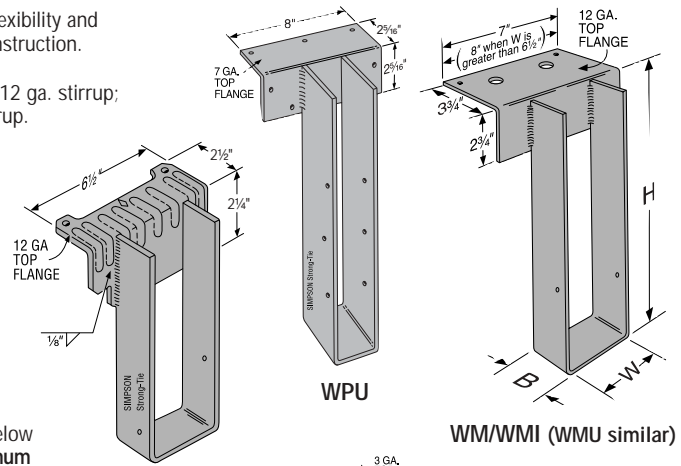

WM/WMI (WMU similar)

Some model configurations may differ from those shown. Contact factory for details.

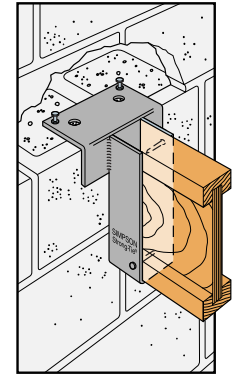

Typical WM Installation with Alternate Nailing Pattern (ANP)

W SERIES WITH VARIOUS HEADER APPLICATIONS

Model	Joist		Fasteners			Allowable Loads Header Type							Code Ref.	
	Width	Depth	Top	Face	Joist	Uplift (133 & 160)	DF/SP LVL ⁴	PSL	LSL	DF/SP	SPF	DF/SCL I-Joist ⁵		Masonry
WI	1 1/2 to 4	3 1/2 to 30	2-10dx1 1/2	—	2-10dx1 1/2	—	1635	1740	—	1600	1415	—	—	170
	1 1/2 to 4	3 1/2 to 30	2-10d	—	2-10dx1 1/2	—	2150	2020	—	2200	1435	—	—	26, 83
	1 1/2 to 4	3 1/2 to 30	2-16d	—	2-10dx1 1/2	—	2335	1950	2335	1765	1435	—	—	—
WMI	1 1/2 to 4	3 1/2 to 30	2-16d DPLX	—	2-10dx1 1/2	—	—	—	—	—	—	—	4175	1, 36, 84, 120
WMU	1 1/2 to 7 1/2	9 to 18	2-16d DPLX	4-1/4x1 1/4" Titens	6-10dx1 1/2	660	—	—	—	—	—	—	4175	170
	1 1/2 to 7 1/2	18 1/2 to 22 1/2	2-16d DPLX	4-1/4x1 1/4" Titens	6-10dx1 1/2	660	—	—	—	—	—	—	4175	
	1 1/2 to 7 1/2	23 to 28	2-16d DPLX	4-1/4x1 1/4" Titens	6-10dx1 1/2	625	—	—	—	—	—	—	4175	
WP/WPI	1 1/2 to 7 1/2	3 1/2 to 30	3-10dx1 1/2	—	2-10dx1 1/2	—	2865	3250	—	2500	2000	2030	—	26, 83 (widths greater than 2")
	1 1/2 to 7 1/2	3 1/2 to 30	3-10d	—	2-10dx1 1/2	—	2525	3250	3650	3255	2525	—	—	
	1 1/2 to 7 1/2	3 1/2 to 30	3-16d	—	2-10dx1 1/2	—	3635	3320	3650	3255	2600	—	—	
WPU/WNPU	1 3/4 to 5 1/2	7 1/4 to 18	3-16d	4-16d	6-10dx1 1/2	775	4700	4880	3650	4165	4165	—	—	26 (widths up to 3 3/16")
	1 3/4 to 5 1/2	18 1/2 to 22 1/2	3-16d	4-16d	6-10dx1 1/2	485	4700	4880	3650	4165	4165	—	—	
	1 3/4 to 5 1/2	23 to 28	3-16d	4-16d	6-10dx1 1/2	315	4700	4880	3650	4165	4165	—	—	
HWI	1 1/2 to 7 1/2	3 1/2 to 32	4-10d	—	2-10dx1 1/2	—	3100	4000	—	5285	3100	—	—	26, 83
	1 1/2 to 7 1/2	3 1/2 to 32	4-16d	—	2-10dx1 1/2	—	5100	4000	4500	5285	3665	—	—	
HWU	1 3/4 to 3 1/2	9 to 18	4-16d	4-16d	6-10dx1 1/2	810	6335	5500	5535	6335	5415	—	—	26
	1 3/4 to 3 1/2	18 1/2 to 22 1/2	4-16d	4-16d	6-10dx1 1/2	765	6335	5500	5535	6335	5415	—	—	
	1 3/4 to 3 1/2	23 to 28	4-16d	4-16d	6-10dx1 1/2	635	6335	5500	5535	6335	5415	—	—	
	1 3/4 to 3 1/2	28 1/2 to 32	4-16d	4-16d	8-10dx1 1/2	1005	6335	5500	5535	6335	5415	—	—	170
	4 1/2 to 7	9 to 18	4-16d	4-16d	6-10dx1 1/2	810	6000	5500	5535	6000	5415	—	—	
	4 1/2 to 7	18 1/2 to 22 1/2	4-16d	4-16d	6-10dx1 1/2	765	6000	5500	5535	6000	5415	—	—	
	4 1/2 to 7	23 to 28	4-16d	4-16d	6-10dx1 1/2	635	6000	5500	5535	6000	5415	—	—	
4 1/2 to 7	28 1/2 to 32	4-16d	4-16d	8-10dx1 1/2	1005	6000	5500	5535	6000	5415	—	—		

1. 16d sinkers (9 ga x 3") may be used where 10d commons are called out with no load reduction.
2. Uplift loads are based on Doug Fir, and have been increased 33% and 60% for wind or earthquake loading; no further increase allowed. Divide by 1.33 and 1.60 for normal loading like cantilever construction.

3. Structural composite lumber is laminated veneer lumber, Parallam® PSL and TimberStrand® LSL.
4. Applies to LVL headers made primarily from Douglas Fir or Southern Pine. For LVL made primarily from Spruce Pine Fir or similar less dense veneers, use the values found in the SPF column.
5. I-joist header with SPF flanges will support 2030 lbs.

Parallam® and TimberStrand® are registered trademarks of Trus Joist, a Weyerhaeuser company.